

Centrometal

HEATING TECHNIQUE

Centrometal d.o.o. - Glavna 12, 40306 Macinec, Croatia, tel: +385 40 372 600, fax: +385 40 372 611

Technical manual

for installation, use and
maintenance of heat pump

R32

ENG

CE





**THE FIRST START-UP MUST BE DONE BY AUTHORIZED PERSON
OTHERWISE PRODUCT WARRANTY IS NOT VALID**

Heat pump Tower-S/170

1. Design and compatibility

1.1 Outdoor units

Table 1.1: Outdoor units

Capacity	6 kW	10 kW	16 kW
Model	SHPAO6RP24CM	SHPAO10RP24CM	SHPAO16RP24P3CM
Power supply (V/Ph/Hz)	220-240/1/50	220-240/1/50	380-415/3/50
Appearance			

1.2 Indoor unit

Table 1.2: Indoor unit

Model	SHPAI60RP24CM-EHT170	SHPAI100RP24CM-EHT170	SHPAI160RP24CM-EHT170
Power supply (V/Ph/Hz)	220-240/1/50		380-415/3/50
Compatible outdoor unit model	SHPAO6RP24CM	SHPAO10RP24CM	SHPAO16RP24P3CM
Appearance			

2. Specifications

Table 2.1: SHPAO6(10)RP24CM specifications¹

Model name			SHPAO6RP24CM	SHPAO10RP24CM	SHPAO16RP24P3CM
Compatible hydronic box			SHPAI60RP24CM-EHT170	SHPAI100RP24CM-EHT170	SHPAI160RP24CM-EHT170
Power supply		V/Ph/Hz	220-240/1/50		380-415/3/50
Heating (A7W35)	Capacity	kW	6.20	10.0	16.0
	Rated input	kW	1.24	2.00	3.56
	COP		5.00	5.00	4.50
Heating (A7W45)	Capacity	kW	6.35	10.0	16.0
	Rated input	kW	1.69	2.63	4.44
	COP		3.75	3.80	3.60
Heating (A7W55)	Capacity	kW	6.00	9.50	16.0
	Rated input	kW	2.00	3.06	5.52
	COP		3.00	3.10	2.90

Table continues on the next page...

...table continued from previous page

Heating (A-7W35)	Capacity	kW	6.10	8.25	13.3
	Rated input	kW	2.00	2.62	4.93
	COP		3.05	3.15	2.70
Heating (A-7W55)	Capacity	kW	5.15	6.85	12.5
	Rated input	kW	2.58	3.43	6.19
	COP		2.00	2.00	2.02
Cooling (A35W18)	Capacity	kW	6.55	10.00	14.90
	Rated input	kW	1.34	2.08	4.38
	EER		4.90	4.80	3.40
Cooling (A35W7)	Capacity	kW	7.00	8.20	14.0
	Rated input	kW	2.33	2.48	5.71
	EER		3.00	3.30	2.45
Seasonal space heating energy efficiency class	Main flow temp. 35°C		A+++		
	Main flow temp. 55°C		A++		
SCOP	Warmer climate	35°C	6.57	7.09	6.28
		55°C	4.21	4.62	4.47
	Average climate	35°C	4.95	5.20	4.62
		55°C	3.52	3.47	3.41
	Colder climate	35°C	4.21	4.32	4.02
		55°C	2.85	2.99	3.12
SEER	Main flow temp. 7°C		5.34	5.98	4.67
	Main flow temp. 18°C		8.21	8.78	6.71
MOP		A	18	19	14
MCA		A	14	17	12
Rated water flow		m ³ /h	1.07	1.72	2.75
Compressor	Type		Twin rotary DC inverter		
Outdoor fan	Motor type		Brushless DC motor		
	Number of fans		1		
Air side heat exchanger	Type		Finned tube		
Refrigerant (R32)	Factory charge	kg	1.50	1.65	1.84
Throttle type		Electronic expansion valve			
Piping connections	Type		Flare		
	Liquid Dia. (OD)	mm	Φ6.35	Φ9.52	Φ9.52
	Gas Dia. (OD)	mm	Φ15.9		
	Min. pipe length	m	2		
	Max. pipe length	m	30		
Installation height difference	Outdoor unit above	m	20		
	Outdoor unit below	m	20		
Sound power level ²		dB	58	60	68
Sound pressure level ³		dB	45	49	55
Net dimensions (W×H×D)		mm	1008×712×426	1118×865×523	1118×865×523
Packed dimensions (W×H×D)		mm	1065×800×485	1180×890×560	1180×890×560
Net/Gross weight		kg	58/64	77/88	112/125
Operating temperature range	Cooling	°C	-5 to 43		
	Heating	°C	-25 to 35		
	DHW	°C	-25 to 43		

Notes:

1. Relevant EU standards and legislation: EN14511; EN14825; EN50564; EN12102; (EU) No 811:2013; (EU) No 813:2013; OJ 2014/C 207/02:2014.
2. Test standard: EN12102-1.
3. Sound pressure level is the maximum value tested under the two conditions of Heating: A7W35 and Cooling: A35W18.

Table 2.2: SHPAI100RP24CM-EHT170 specifications

Model name		SHPAI60RP24CM-EHT170	SHPAI100RP24CM-EHT170	SHPAI160RP24CM-EHT170	
Compatible outdoor unit model		SHPAO6RP24CM	SHPAO10RP24CM	SHPAO16RP24P3CM	
Function		Heating, cooling and DHW			
Setting water temperature range	Cooling	°C	5 to 25		
	Heating	°C	25 to 65		
	DHW ³	°C	30 to 60		
Power supply		V/Ph/Hz	220-240/1/50		
Sound power level ¹		dB	38	42	
Sound pressure level (1m) ²		dB	28	30	
Dimension (W×H×D)		mm	600×2010×600		
Net/gross weight		kg	230/240		
Water circuit	Piping connections		R	1"	
	Safety valve set pressure		MPa	0.3	
	Drainage pipe connection		mm	Φ25	
	Buffer tank volume		L	30	
	Expansion vessel	Volume	L	8.0	
		Max. water pressure	MPa	0.3	
		Pre-pressure	MPa	0.1	
	Water side heat exchanger	Type	Plate type		
	Water pump head		m	9	
	Water flow range		m ³ /h	0.4~1.25	0.4~2.10
DHW	DHW tank volume		L	170	
	DHW expansion vessel		L	11	
	Connections		R	3/4"	
	Safety valve set pressure		MPa	0.6	
	Optional electric heater		kW	2	
Backup electric heater	Standard	kW	3	9	
	Capacity steps		1		
Refrigerant circuit	Liquid Dia. (OD)	mm	Φ6.35	Φ9.52	
	Gas Dia. (OD)	mm	Φ15.9		
Room temperature range		°C	5 to 35		

Notes:

1. Test standard: EN12102-1.
2. Sound pressure level is the maximum value tested under the two conditions of Heating: A7W35 and Cooling: A35W18 for different combination between outdoor unit and hydronic box.
3. Maximum domestic hot water temperature 60°C is only available with DHW heater support.

3. Dimensions

3.1 Outdoor units

Figure 3.1: SHPAO6RP24CM dimensions (unit: mm)

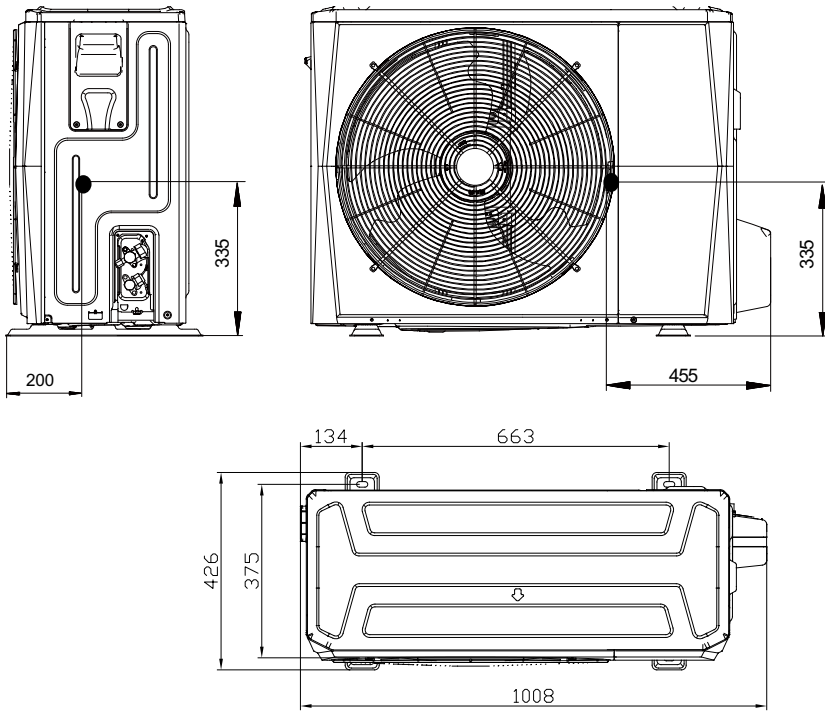
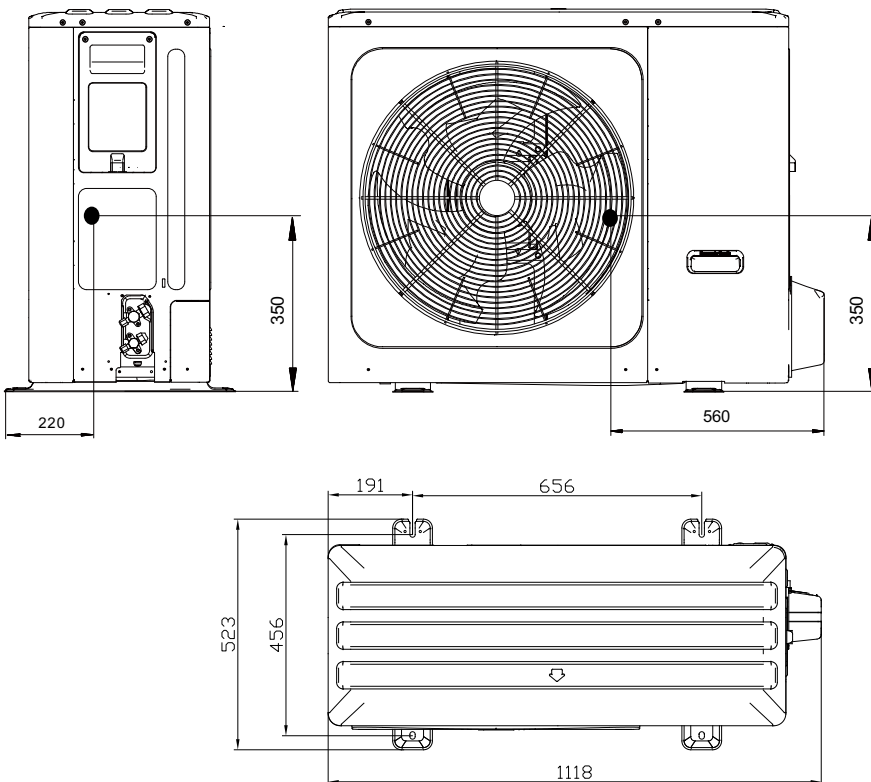
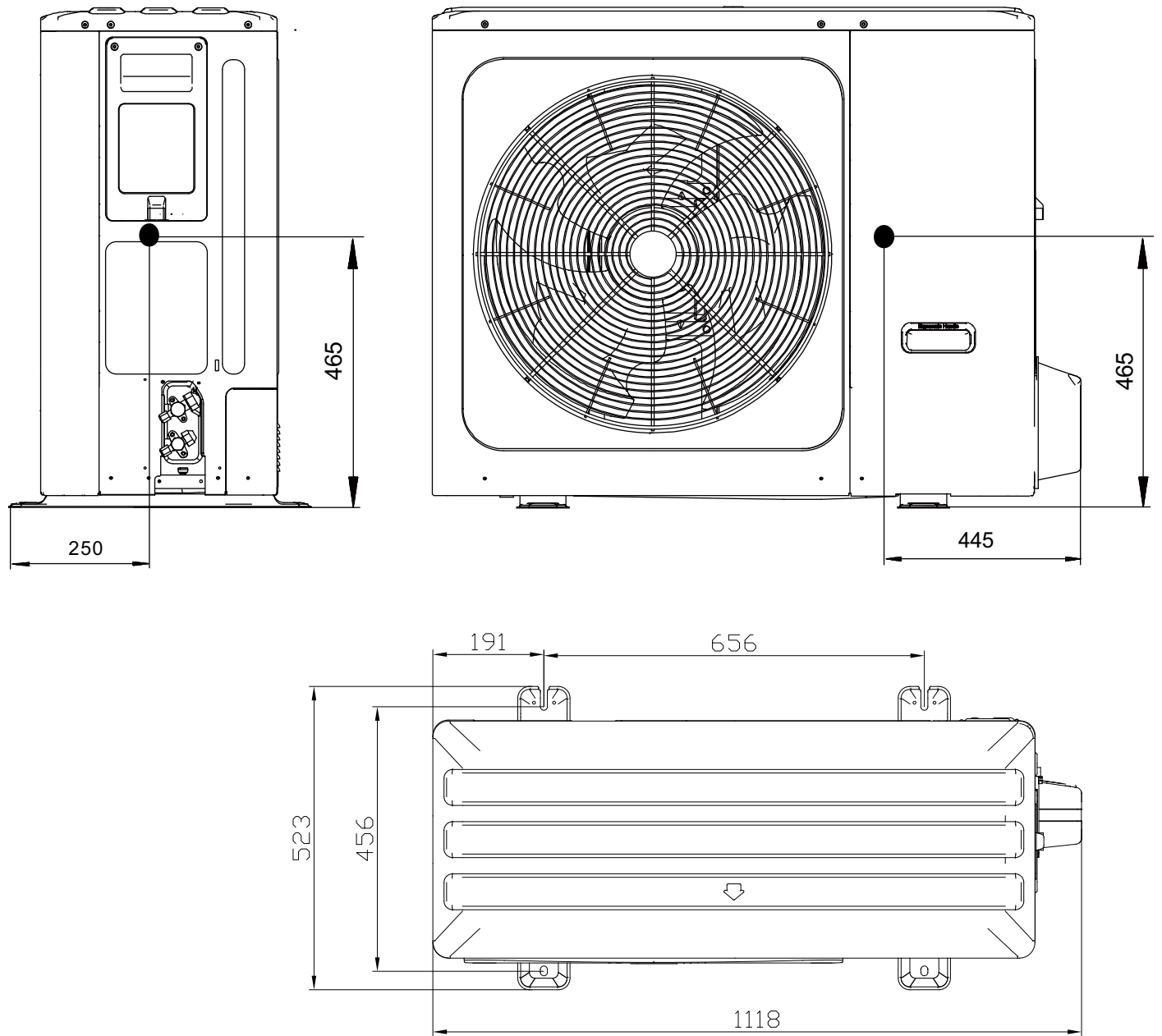

Figure 3.2: SHPAO10RP24CM dimensions (unit: mm)



SHPAO16RP24P3CM

Figure 3.3: SHPAO16RP24P3CM dimensions (unit: mm)



3.2 Indoor unit

Figure 3.4: SHPAI60(100,160)RP24CM-EHT170 dimensions (unit: mm)

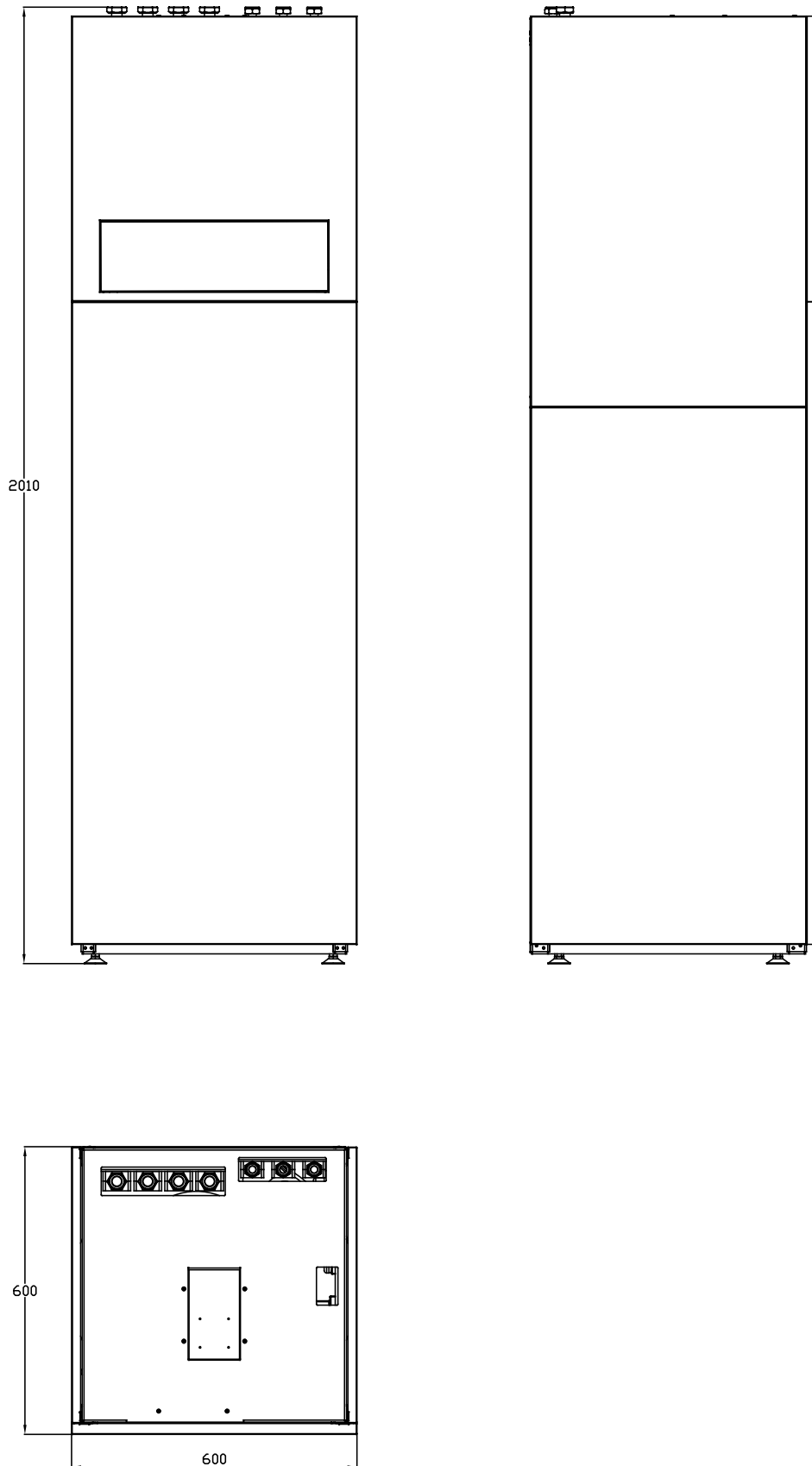

4. Wiring diagrams

Wiring diagrams of outdoor units SHPAO6RP24CM, SHPAO10RP24CM and SHPAO16RP24P3CM can be found in technical manual "Heat pumps Arctic Split series". Wiring diagram of indoor unit SHPAI60(100,160)RP24CM-EHT170 is shown on page 22 of technical manual "Heat pumps Arctic Split series". Wiring diagram of control unit HPCU360iCM (black box + panel) can be found in technical manual "Technical manual for control unit" on page 23.

It is necessary to connect power supply cable of indoor heat pump unit and communication cable between indoor and outdoor unit inside distribution box placed on top of the Tower heat pump. Wiring diagram is shown on picture 4.1.

Figure 4.1: Indoor unit wiring diagram

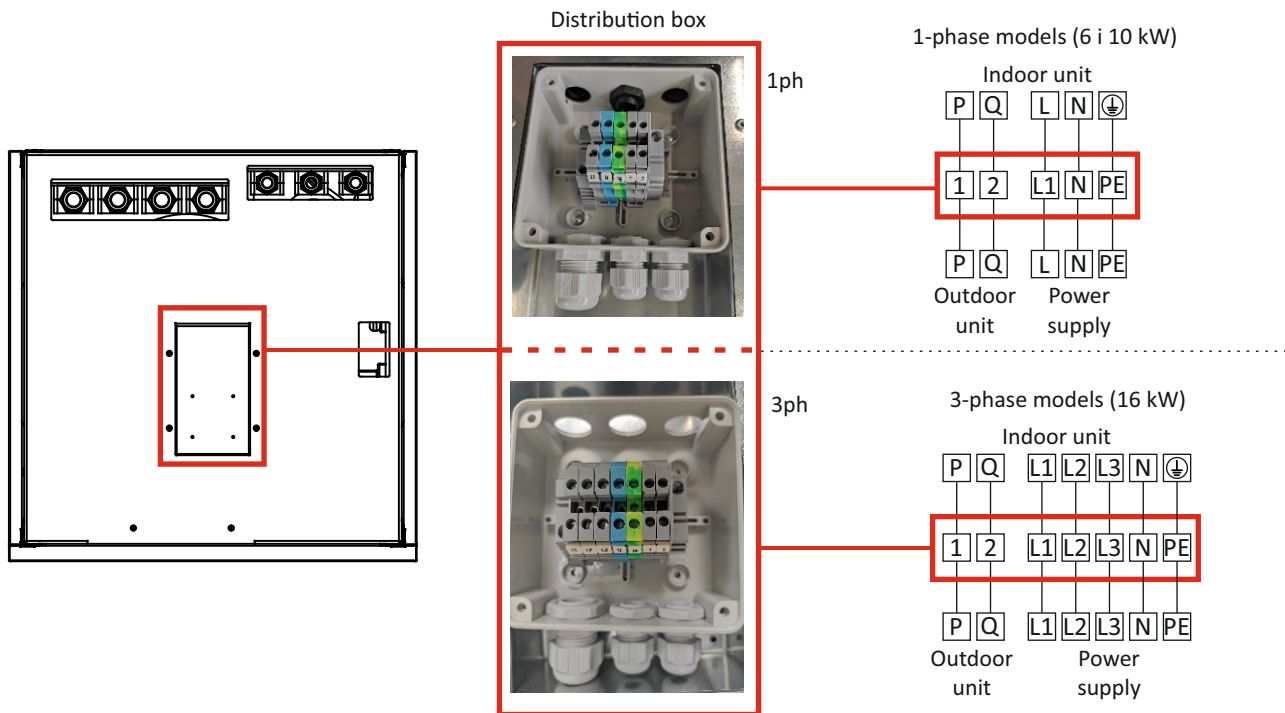

After connecting the power supply, turn the main switch in position "1". If control unit digital display does not turn on, check the main switch of control unit HPCU360iCM (black box placed behind electronics).

Figure 4.2: Placement of elements behind black glass

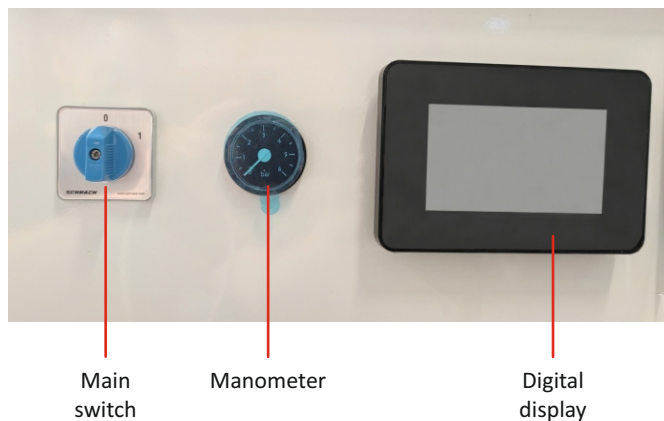

5. Installation and connection to the heating and cooling system

5.1 Outdoor unit installation

For installation and connection of outdoor and indoor unit follow directions given in Part 3 of technical manual "Heat pumps Arctic Split series".

5.2 Indoor unit installation

Figure 5.1: Heat pump Tower-S/170 scheme

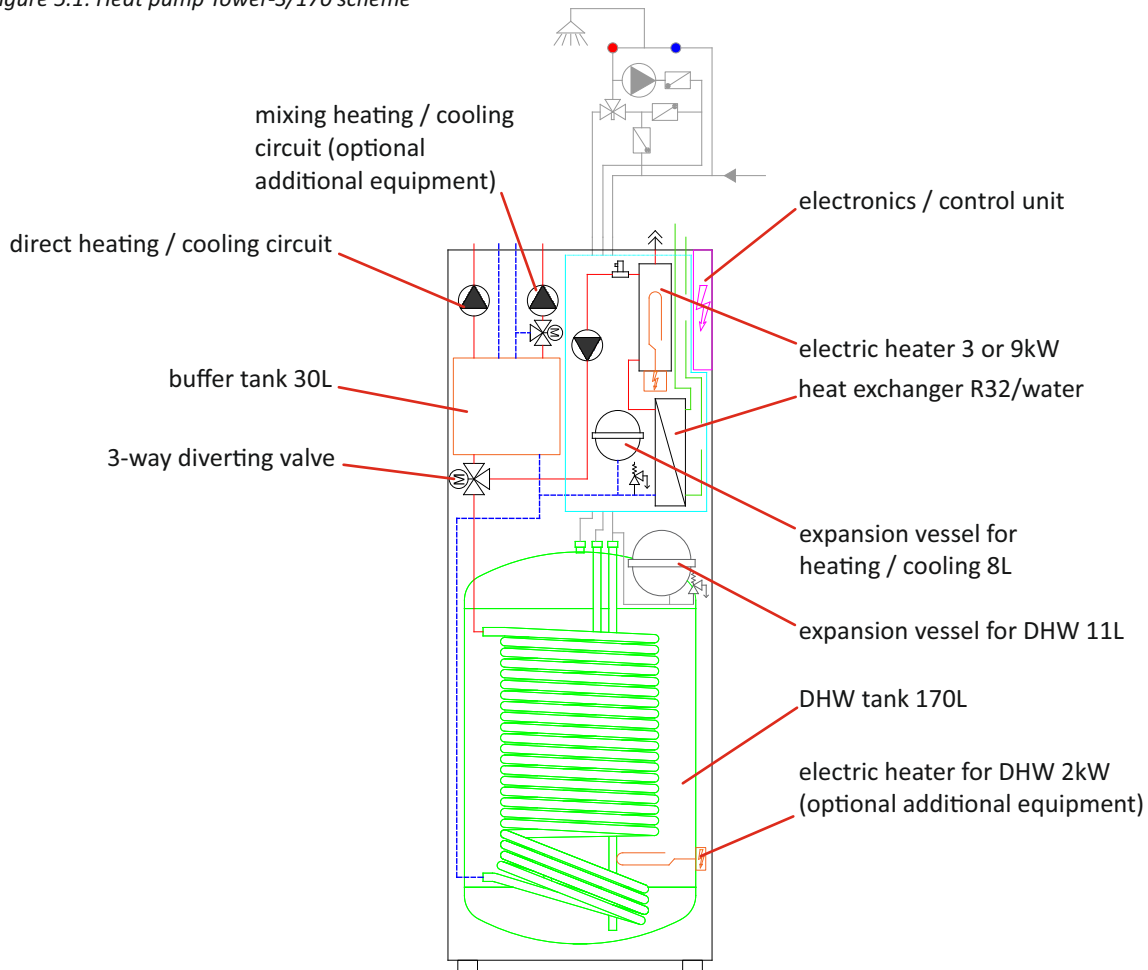

The pipes of the heating / cooling system are connected to the indoor unit with straight connectors. It is necessary to follow the labels in Figure 5.2. The flow and return of the mixing heating circuit only exist if the mixing heating circuit is selected as an additional equipment.

Figure 5.2: Tower heat pump top view with labeled connections

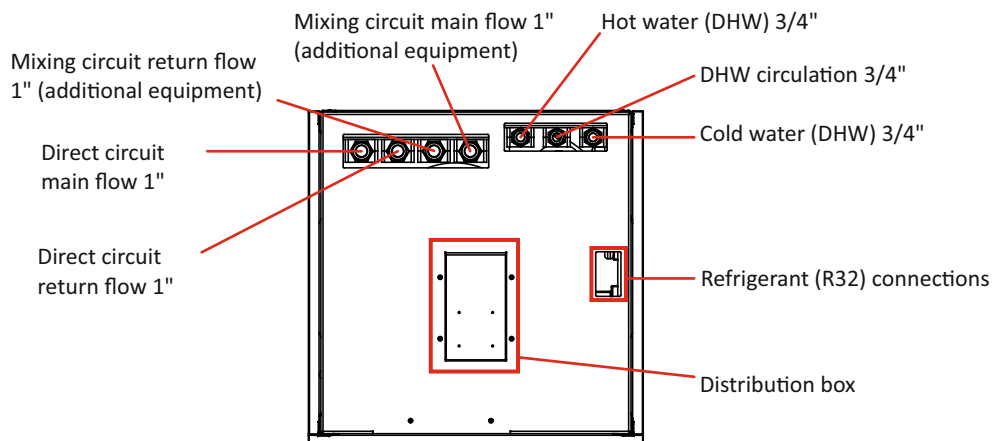

5.3 Installation and connection of mixing circuit (HPT-MC) - additional equipment

Mixing heating circuit is additional equipment and, if selected, it should be mounted on Tower unit.

Mixing circuit set consists of:

- 3-way mixing valve
- motor actuator of 3-way mixing valve
- circulation pump for heating circuit
- insulated pipes
- heating circuit temperature sensor

Mixing heating / cooling circuit set must be connected with a straight connector to the connection on the buffer tank (factory installed plug). The set needs to be fixed with a clamp from the top side, at the exit from the Tower unit. Mixing valve motor actuator must be installed according to manual delivered with the motor actuator. Additional mixing circuit is installed according to figure 5.3. Mixing valve motor actuator should be facing inside of the unit. The pump and the motor actuator of the three-way mixing valve must be connected to the HPCU360iCM control unit at ports 17, 18, PE - pump, and 6, 7, 8, PE - motor actuator of the three-way mixing valve according to the diagram in Figure 5.4. The heating circuit temperature sensor must be installed under the pipe insulation after the circulation pump (figure 5.3) and connected to the HPCU360iCM control unit (ports 41, 42). The mixing heating circuit must be enabled and adjusted in the control unit settings. After installation of the additional mixing valve, system should be filled with water and checked for any leakage.

Figure 5.3: Installation of additional mixing circuit HPT-MC

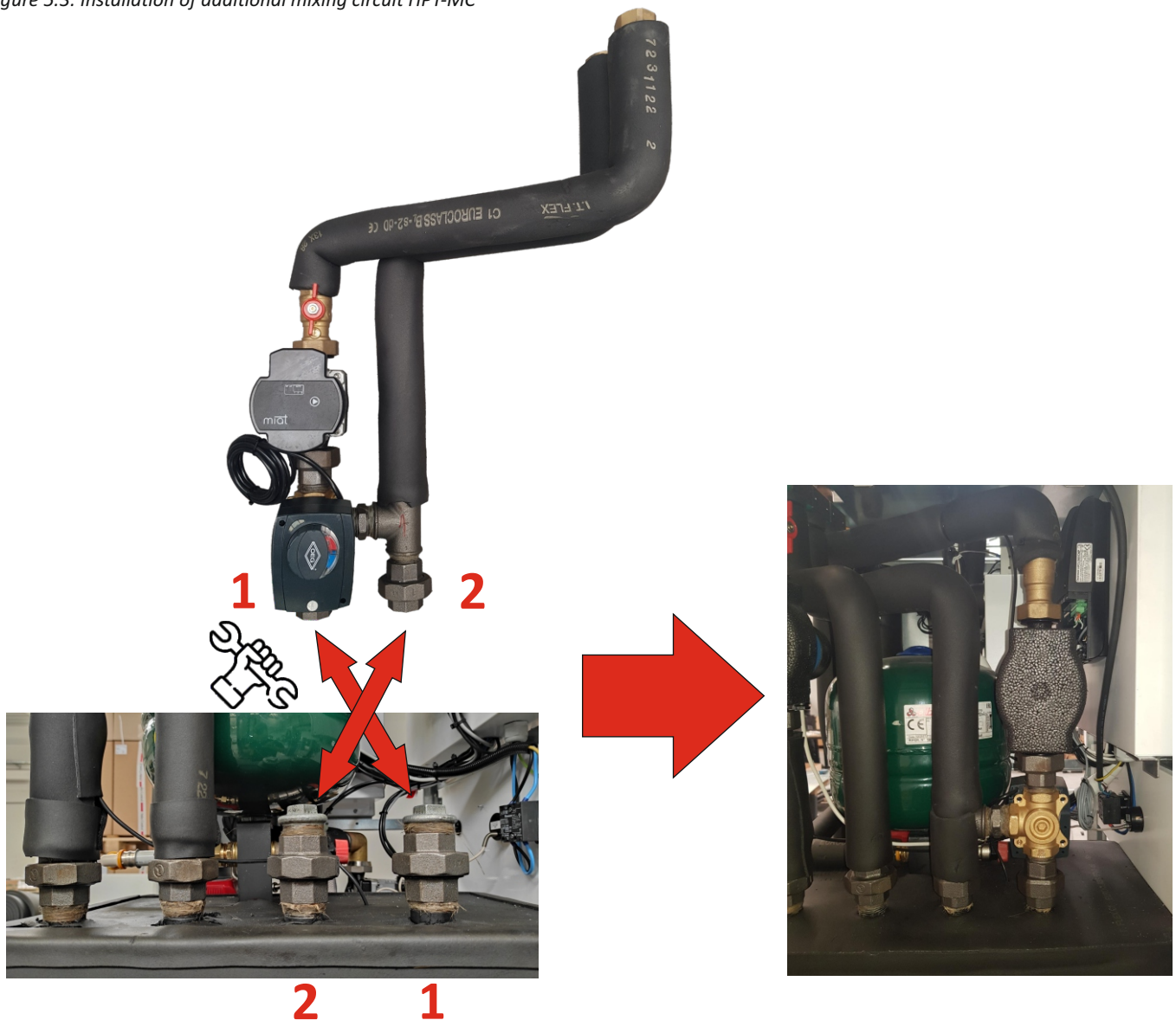

Figure 5.4: Control unit HPCU360iCM wiring diagram - additional mixing circuit

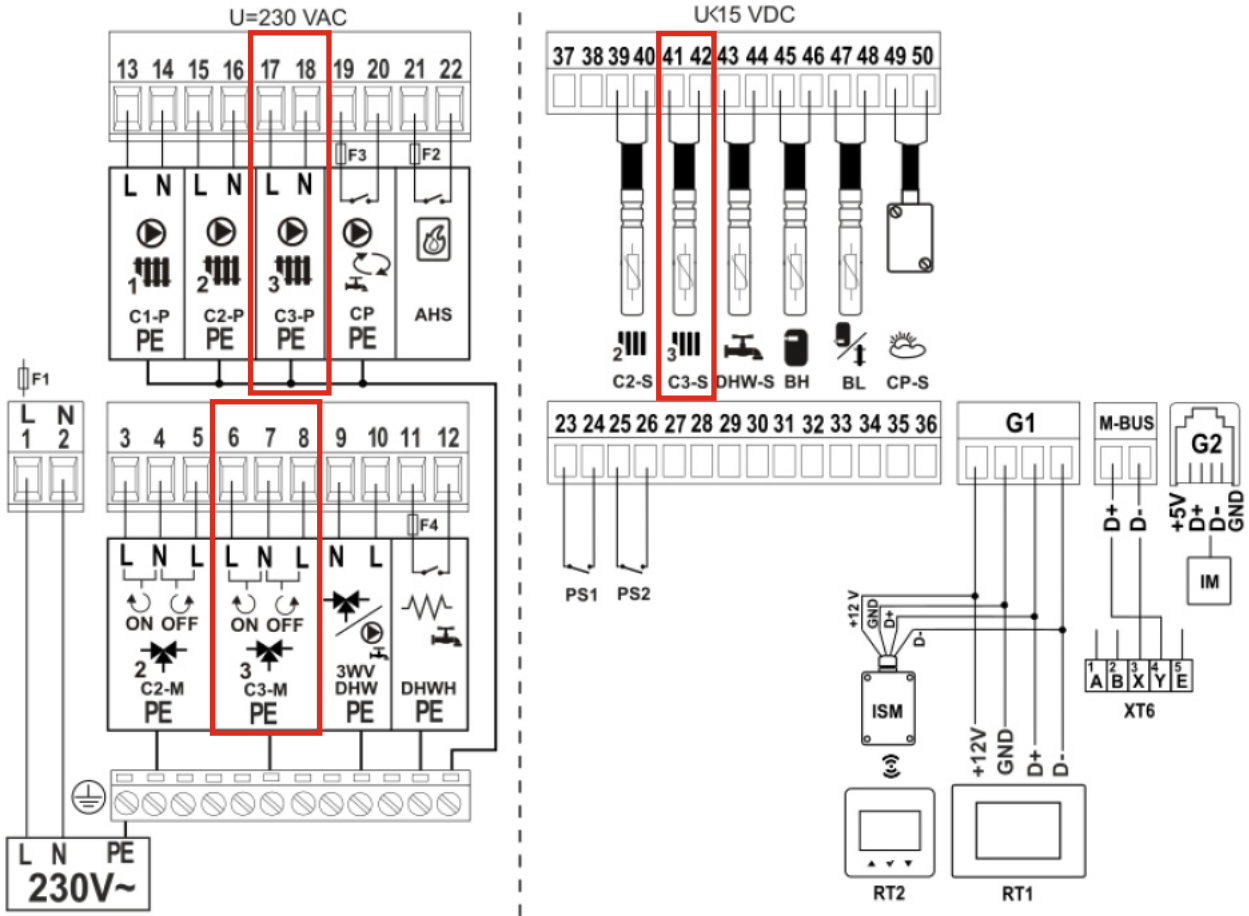
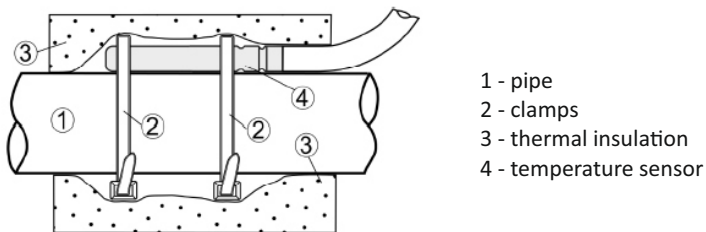

Figure 5.5: Additional circuit temperature sensor installation





Company assumes no responsibility for possible inaccuracies in this book originated typographical errors or rewriting. All the pictures and diagrams are principal and it is necessary to adjust each actual situation on the field, in any case the company reserves the right to enter their own products such modifications as considered necessary.

Centrometal d.o.o. Glavna 12, 40306 Macinec, Croatia

central tel: +385 40 372 600, fax: +385 40 372 611
service tel: +385 40 372 622, fax: +385 40 372 621

www.centrometal.hr
e-mail: servis@centrometal.hr

Centrometal
HEATING TECHNIQUE
